



**PLECTERE**  
ACOUSTIC TEXTILE DESIGN ©

# transforming your space



Plectere brings peace, comfort and tactility to a space and thus improves the acoustics. Plectere is an object made of wool felt strips with which acoustic partitions and room dividers can be made. It improves the experience of a space through its excellent acoustic properties. The object is visually attractive because of the 3D structure with an intriguing, repeating pattern.

Plectere exhibits a remarkable acoustic function by weaving the felt into a 3D structure. Because of its transparency, users can demarcate spaces without completely sealing them off. Plectere can be delivered as a divider, in a wooden frame or applied in a 3D object.

When Plectere is hung in front of a glass wall with a spatial cavity, it absorbs both high and low frequency sound waves.

Plectere acoustic room dividers embody a new application for the venerable material felt: the result is design innovation for the material and its applied technique.



IMPROVES WELLBEING

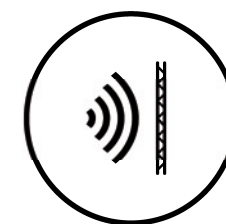

ACOUSTIC PERFORMANCE

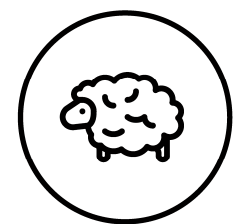

100% NATURAL MATERIAL

## enhanced acoustics & aesthetics



We demand a lot from our employees and that alone requires a pleasant and efficient working environment. Acoustics and atmosphere play an important role in work areas.

Noise and distractions in the workplace consistently come up in the top factors that affect people's wellbeing. Enhanced privacy, acoustics, comfort and tactility help employees not only to feel better, but also to perform better.

As a highly flexible product, Plectere can be introduced at any point in the design process as semi-transparent space dividers to delineate different work areas. It can also be applied to existing workspaces to specify work areas while providing more privacy and comfort. It is easily relocated, so it can adapt to the changing demands of the environment.

Plectere offers a solution for spaces where acoustic improvement and more tactility is desired.

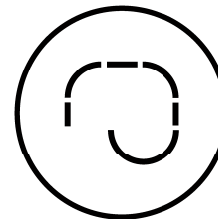

FLEXIBLE FUNCTION

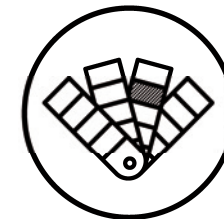

VARIOUS COLOURS

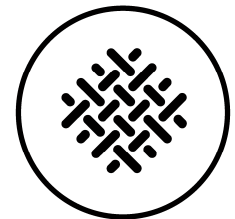

TRANSPARENCY

## colours & materials



Plectere is available in various colours, check our colour chart for all options.

The Ecrú mélange 002 colour is deliverable within 7 weeks. The delivery time for Plectere in other colours is 7 to 12 weeks. It is also possible to choose your custom felt colours, please let us know and we will check the options.

Plectere in ecru mélange is available by the piece. Other colours from the colour chart demand a minimum order size of 6m<sup>2</sup> per colour.

The felt strips are 5 mm thick.

From 2021 Plectere is also available in 100% Dutch wool felt. This Plectere ecru mélange is not dyed and has the natural light yellow wool colour.

## 100% Dutch wool



Almost all the wool that we use in the Netherlands originates from Australia, New Zealand or South Africa. Until recently most of the Dutch wool was exported to China, but due to the rising transport costs, this now has become too expensive. Today it is cheaper to throw the wool away than to have it processed.

Plectere has teamed up with The Knitwit Stable to change that. Their ambition is to maintain the use of local wool within the national borders and to bring the entire chain back to the Netherlands on a professional scale. That is why The Knitwit Stable collects the Dutch wool needed for the felt of the Plectere elements. The Kempian heather sheep are shorn, the wool is sorted and twigs, hay, manure and other dirt is removed, so that only the usable wool remains. Because there is no wool processing industry in the Netherlands, Studio Petra Vonk has the wool washed in Belgium and felted in Italy. Back in the workshop in Amsterdam, the felt is braided by hand into the Plectere panels.

The wool used for Plectere comes from a herd for landscape management De Wassum, with more than 1.000 Kempian heather sheep grazing heath areas in East Brabant and North Limburg. Each sheep delivers up to 3.5 kilos of wool. Because the sheep roam free, all kinds of plant material is trapped in the fur. Because the wool is only washed and not carbonized, some of the vegetable fibres remain in the wool. These speckles give the unique natural character to the felt.

The Dutch wool felt is a non-woven textile, produced from raw wool fibres that undergo a wet felting process of matting, condensing and pressing. This age-old process uses only natural ingredients, including sheep's wool, water and vegetable fibres. The Plectere ecru mélangé is undyed and has the natural light yellowish wool colour.

## aline hanging



The Plectere\_aline hangs beautifully straight and is very firm as a result of the tube incorporated at the bottom and top. Plectere\_aline is delivered with thin steel cables and cable clamps for easy installation.

Available standard sizes (width x height):

± 125cm x ± 175cm	± 160cm x ± 200cm
± 125cm x ± 200cm	± 200cm x ± 200cm
± 125cm x ± 250cm	± 200cm x ± 300cm

Customization is possible on request. The maximum height of Plectere\_aline is 345cm. There is no limit as to the width. Because Plectere is a handmade product, there are always small deviations in size. For the standard Plectere, there is a margin of ± 5 to 10 cm on all sides.

### Colours

Can be chosen from our colour chart.

Ecru mélange is deliverable within 7 weeks.

Other colours 7-12 weeks.

Custom colours are also available.

### Minimum quantities

Plectere in ecru mélange is available by the piece.

Other colours from the colour chart have a minimum order size of 6m<sup>2</sup> per colour.

### Weight

± 2-3 kg per m<sup>2</sup>









## curve hanging



Because Plectere is in fact an enlarged knit, it also behaves like a knitted cloth. Plectere can therefore be applied in a playful organic form so that a semi-transparent concentration workplace can be demarcated.

Plectere\_curve is a quarter of a circle (circle diameter of 1800 mm) that can be extended at both ends with one or more rows (middle piece) up to the desired width. The side is closed with an end row (left and right).

The maximum height of Plectere\_curve is 345cm. There is no limit as to the width. Because Plectere is a handmade product, there are always small deviations in size. For the standard Plectere, there is a margin of  $\pm 5$  to 10cm on all sides.

### Colours

Can be chosen from our colour chart.

Ecru mélange is deliverable within 7 weeks.

Other colours 7-12 weeks.

Custom colours are also available.

### Minimum quantities

Plectere in ecru mélange is available by the piece.

Other colours from the colour chart have a minimum order size of 6m<sup>2</sup> per colour.

### Weight

$\pm 2-3$  kg per m<sup>2</sup>

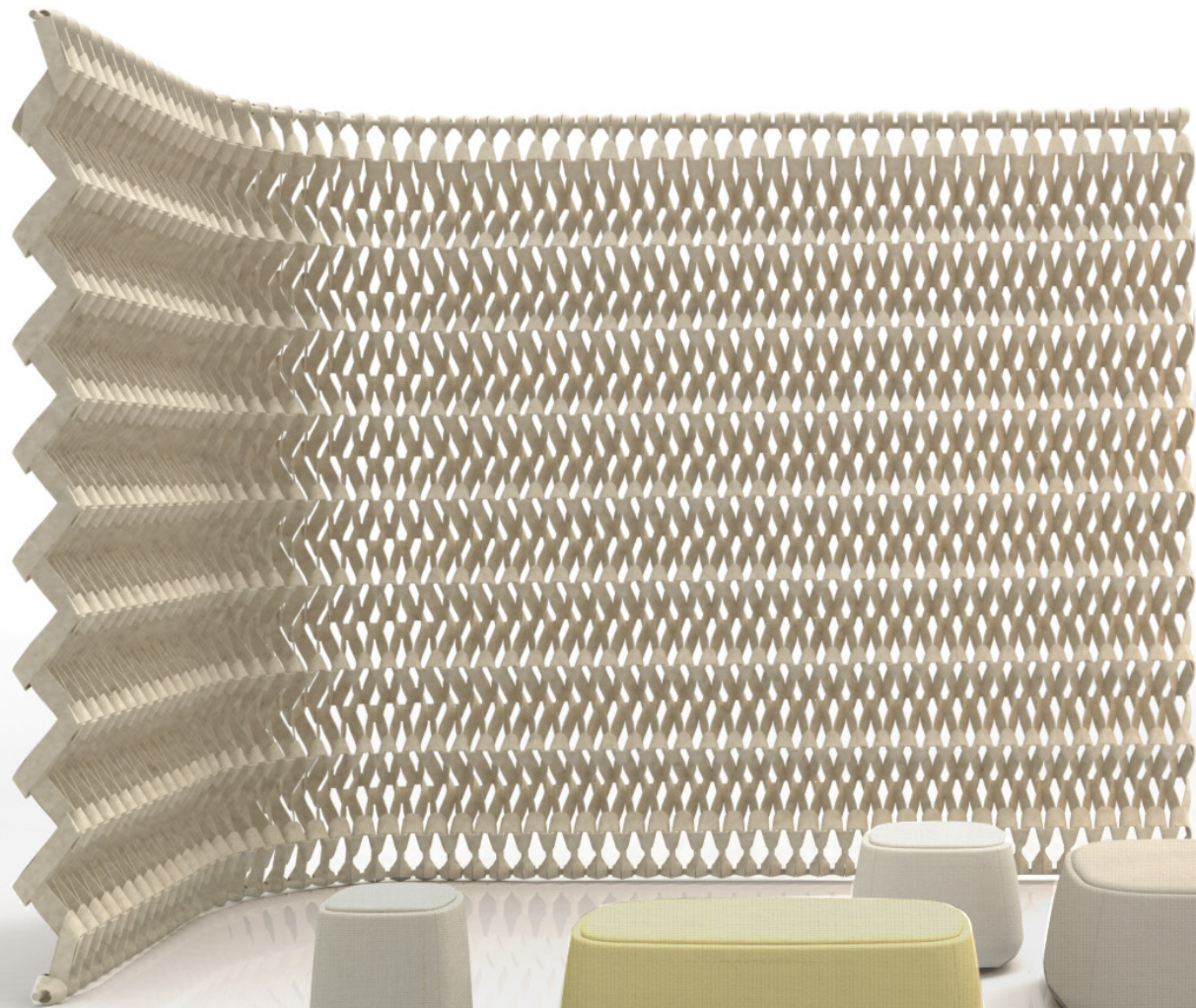



HOTEL DE L'OPERA  
TOUR  
< RESTAURANT

## frame stand alone



### Finished ash wood frame

Standard dimension 125 cm (b) x 175 cm (h)  
+ supporting legs = 200 cm height

### Colours

Unicolours and duotone colours can be chosen from our colour chart. Ecrú mélange is deliverable within 7 weeks.

Other colours 7-12 weeks.

Custom colours are also available.

### Minimum quantity

Plectere duotone numbers on request.

### Weight

± 4-5 kg m<sup>2</sup>



## re\_play hanging



Plectere re\_play is composed of 9 strips of wool felt, sewed together to a total width of 45 cm. The upper and lower part of the element is completely closed, the opening curved part is 70 cm high and at view height when standing. The total element is 200 to 250 cm high, but all sizes can also be customised.

The felt used are the leftover strips from the Plectere production process in combination with remnants from felt suppliers. This means they sometimes have little holes and spots and most certainly have colour differences as a result of the different colour batches.

For various reasons - breeding, isolation or disease - sheep can be labeled with pigment. Sometimes these pink, blue or brown dots remain in the wool. Because the wool felt is never treated with chemicals, such as bleach to whiten these stains, these dots can be visible and are proof of the natural origin of the material. This is precisely one of the qualities of the re\_play collection.

### Available dimensions

Standard height  $\pm$  250 cm, width  $\pm$  45 cm per strip.  
Other dimensions on request.

### Colours

Depending on production residues, colour combinations are possible on request.

### Weight

$\pm$  1 kg m<sup>2</sup>





## specials

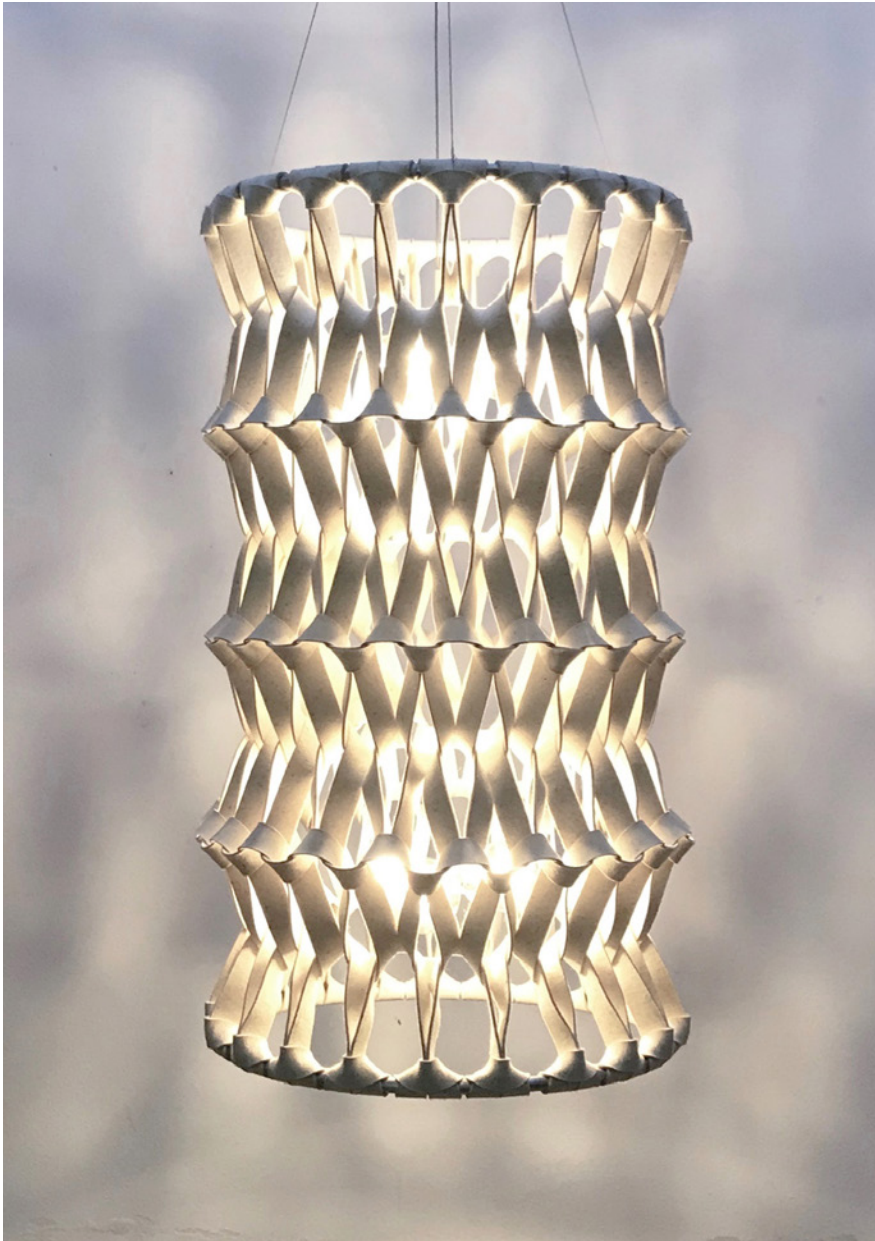

Studio Petra Vonk is happy to assist in custom Plectere solutions.

The flexible structure of Plectere creates many options in terms of shape and elaboration. Please find some examples of custom-made Plectere below: panels in a wooden frame, Plectere as a hanging object in an open space or Plectere as lighting object.

Plectere creates both a visual and an acoustic effect.





# acoustic performance

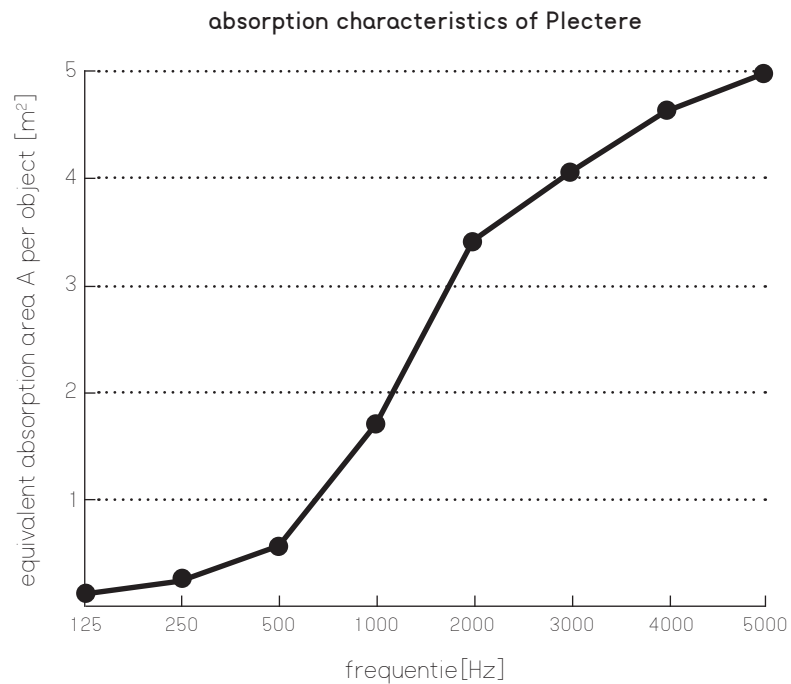

The acoustic report shows very nice test results. Plectere offers medium to high absorption for mid and high frequencies.

Disturbing high frequencies from adjacent workplaces are immediately reduced by 25% despite the transparency of Plectere. Plectere thus significantly improves acoustic comfort.

When Plectere is applied with a cavity to the wall, the sound absorption is slightly higher due to the visual and acoustic transparency of Plectere. When using a cavity between 12 and 32 cm, the acoustic effect remains almost as good. Thus giving a lot of freedom in the application of Plectere.

If Plectere is applied as an object in a space, the absorption properties will be slightly lower than when used as a plane absorption closer to a wall, simply because of physical reasons.

## 3D files

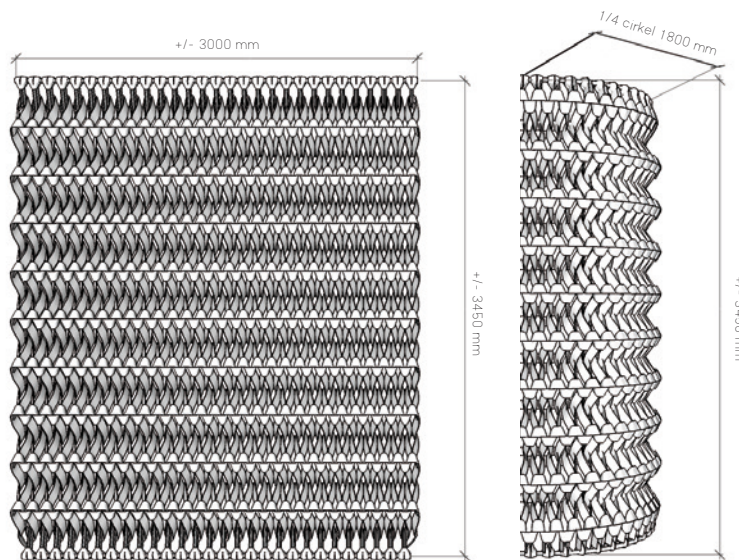
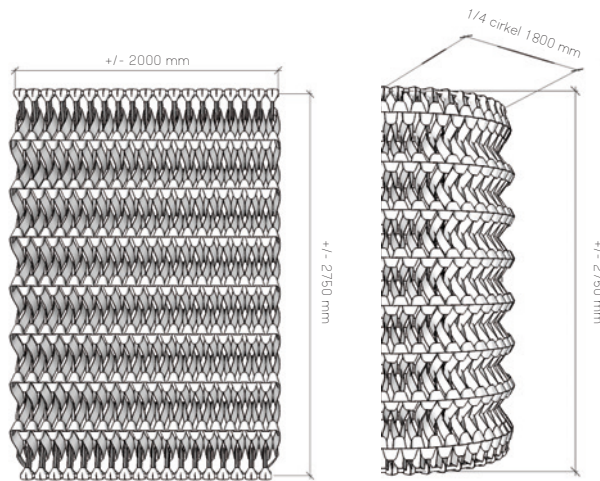
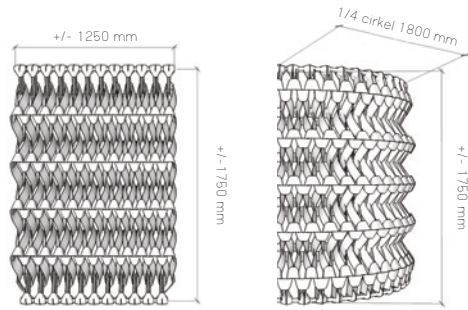

Plectere is available in 6 different heights:  
± 1750 mm | ± 2000mm | ± 2350mm | ± 2750mm |  
± 3050mm | ± 3450mm

Plectere is available in every width. You can request our 3D drawing files via the [plectere.nl](http://plectere.nl) website, which makes it easy to include Plectere in your interior design. In the 3D files the width is dynamic and scales automatically with your drawn width.

Plectere\_curve is a quarter of a circle (circle diameter of 1800 mm) which can be extended at both ends with one or more rows (middle piece) up to the desired width. The side is closed with an end row (left and right).

It is possible to combine Plectere\_aline and Plectere\_curve, for example Plectere\_aline of 1750 mm (h) x 1250 mm(w) combined with a Plectere\_curve of 1750 mm (h).

The height is not adjustable because of the pattern and the height of the felt loops. Please allow a margin of 5 - 10 cm for the sizes; Plectere is a handmade product.

Examples of shapes when combining Plectere\_aline and Plectere\_curve:



## installation + maintenance

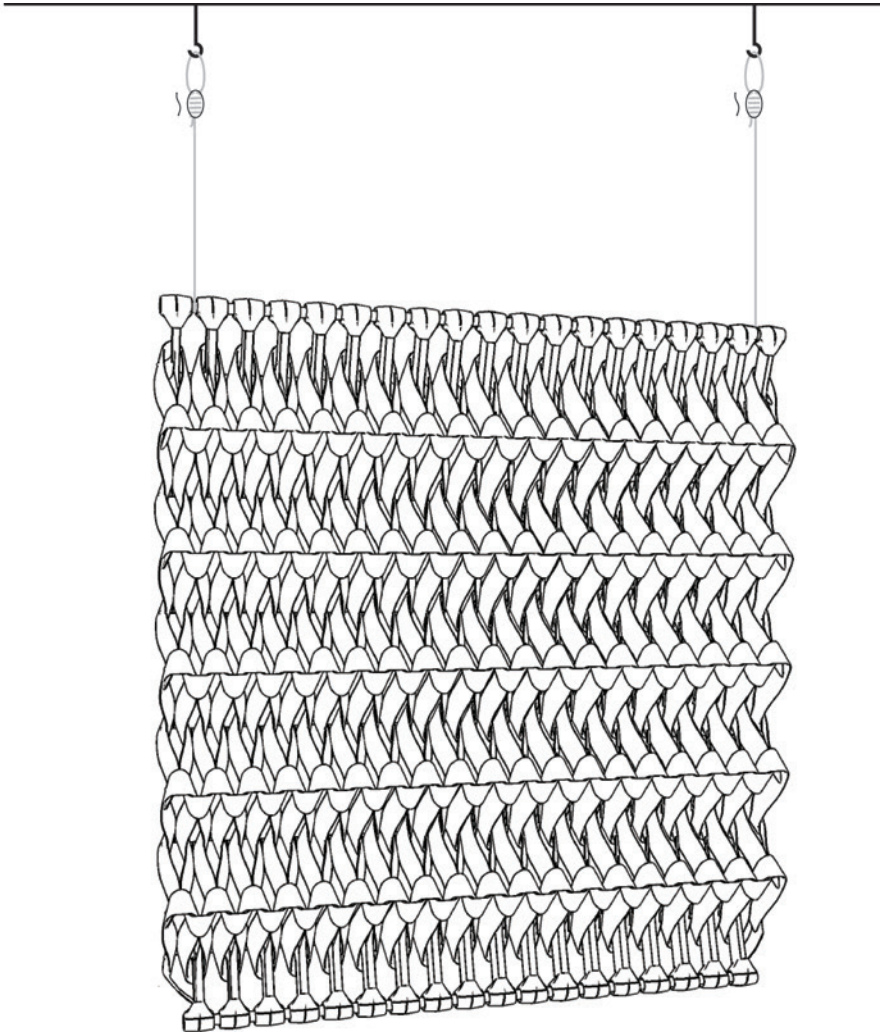

Plectere is easy to install. Plectere is delivered rolled up with steel cables attached to the tube. Unpack the Plectere, install 2 or 3 hooks in the ceiling, run the steel cables through. The self-clamping cable clamps make it is easy to raise and level Plectere.

Plectere\_frames without stands can be hung on the ceiling as desired. Placing Plectere\_frames in a rail in the ceiling creates the possibility to slide the frames according to user needs.

### **Maintenance**

Plectere is a low-maintenance product. An important advantage of wool is its anti-static nature: it repels dust. Therefore, cleaning with a feather duster once a month is all that is required.

## history + journey

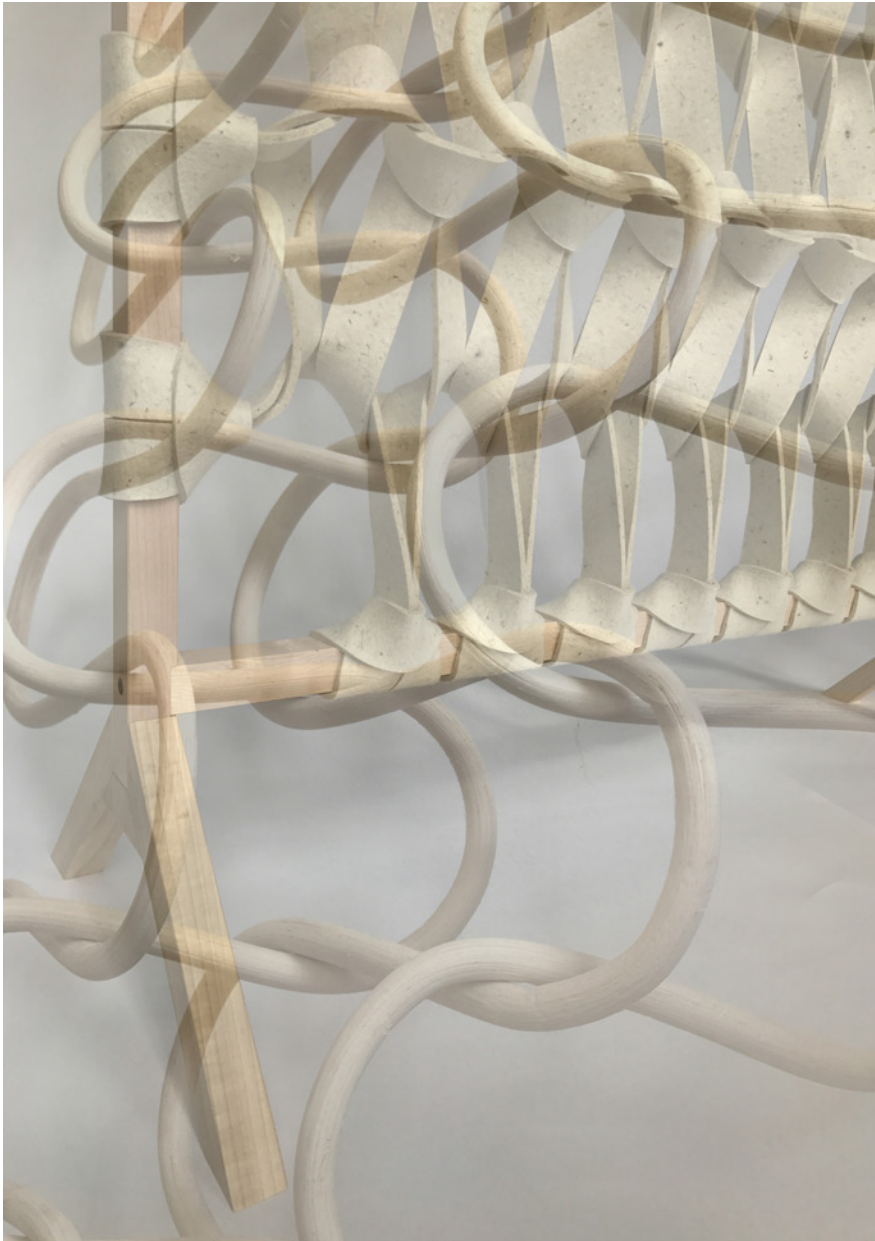

Developing Plectere has been a long journey. It started with a desire to experiment with combining knitting techniques with exceptional textiles, which motivated me to develop patterns with rattan. This resulted in a unique structure with unprecedented stability that could not have been realized with a knitted object. It also opened the way for the further development of a stable 3D knit.

From there, I produced knitted lace patterns from 100% wool. After felting the wool, a beautiful new 3D structure enabled us to apply it to acoustic panels. The felt did not have the same stability as rattan but was an important phase in the evolution of Plectere.

The original idea to make an oversized knit from rattan took years to develop through various collaborations with architects, landscape architects, designers, students and trainees. By connecting all these different points of view, we decided in the end that industrial woolen felt was optimal for Plectere.

Plectere is a local Dutch product. The industrial felt is 100% bio-based and woven by hand from beginning to end. This is where the product got its name. Plectere means 'to weave' in Latin. The wooden frames that we use are made from beautiful ash wood. The wood frames and Plectere pieces are sustainably produced in and around Amsterdam.

Petra Vonk

## about **studio petra vonk**



Dutch designer Petra Vonk launched her Amsterdam textile design studio after graduating from the Design Academy Eindhoven. After years of working in the fashion industry she switched to designing textiles for interior architecture and interior products.

Playing with the characteristics that are bound within specific materials and techniques, Petra creates often new and unexpected concepts and applications. Through the use of repetition in abstract pattern designs, her designs experiment with transparency, while contrasting materials and progressive techniques arouse curiosity.

Design objects display expressive visual and tactile qualities with an emphasis in functionality, be it to enhance the acoustic properties of a space or offer intimacy to an interior by means of impenetrable graphic patterns. Petra is working in close collaborating with architects and interior designers resulting in innovative textiles and their uses.



studio **Petra Vonk** textile design

Plectere is designed by Studio Petra Vonk  
Blokmakerstraat 22  
1013 DH Amsterdam, Netherlands

[www.plectere.nl](http://www.plectere.nl)

[focus@plectere.nl](mailto:focus@plectere.nl)

+31 6 22 77 73 34

[www.petravonk.nl](http://www.petravonk.nl)

[info@petravonk.nl](mailto:info@petravonk.nl)